



361-884-8006 Sales

Owner and Installation Manual For:

EZ-4000

**LOW ENERGY AUTOMATIC SWING
DOOR OPERATOR**

PLEASE READ THIS ENTIRE MANUAL AND FOLLOW ALL GUIDELINES TO
ENSURE PROPER INSTALLATION AND SAFETY

PROUDLY DISTRIBUTED BY...



ANSI/UL 991, 325 & CAN/CSA 27 Listed
REV. 11/13/19



READ THIS FIRST!



Quick Start Guide

Caution: When used in a low energy installation, the EZ-4000 operator and associated ES500 control *must* be installed and adjusted in accordance with ANSI 156.19.

Warning: The ES500 control **must** remain connected to the operator at all times. **Never** leave the operator without a control connected, as the closing speed will be uncontrolled and may cause severe damage to the operator or door. Manual operation must **never** be permitted with the control removed.

Attention: This unit has been pre-programmed to a generic 90-degree opening position. Please follow the instructions below.

1. Plug in the wiring harness from the controller to the operator.
2. Plug in the **Hold-Automatic-Off (HOA)** harness **ONLY**. Do not plug in any additional accessories, i.e. safety switches, door lock switches or actuating devices.
3. Plug in motor and check for polarity. (Motor should return slowly to the stop position if wired correctly).
4. Plug in power supply. Turn **HOA** switch to the **HOLD** position. The motor should open to the full hard stop position.
5. Install arm and check the outside cam. The cam switch should be in the down position (flat part of cam).
6. Turn power off and let door close completely. Check inside cam. The switch should be in the down position (flat part of cam)
7. Turn power on. After a couple of seconds, the **Id** light should be on. Test door by pressing the **Down** button on the control board.

You are now ready to fine tune the Controller and install accessories. Please refer to the **ES500 Swing Control Installation** instructions attached.

Note: Due to the method used for synchronization, it is not possible to have different values for the standard delay (**d1**) and the close recycle delay (**d3**). Delays **d1** and **d3** should be set to the same value in each operator, and must also be set identically on both operators. The push-n-go delay (**d2**) may be different from **d1/d3**, but should also be set identically on both operators. This restriction does *not* apply to single operators.



CAUTION

- ⚠ An improperly installed and/or adjusted Automatic Door can cause injury and equipment damage.
- ⚠ Door must be installed and adjusted as described in this Owner's Manual by a certified professional.
- ⚠ All required safety devices must be in place and operational.
- ⚠ Door must be inspected DAILY. If the door is not functioning correctly it must be taken out of Automatic Service immediately until a Certified Technician inspects and repairs the unit.

**DO NOT ATTEMPT TO ADJUST OR REPAIR THE DOOR YOURSELF
CALL YOUR AUTOMATIC DOOR SUPPLIER FOR REPAIRS**

To our Customers

The purpose of the manual is to familiarize you with your automatic door system. It is essential that you know your system and that you recognize the importance of maintaining your door system in compliance with the industry standards for safety.

It is your responsibility, as owner or caretaker of the equipment, to inspect the operation of your door system on a daily basis, and after any loss of electrical power, to ensure that it is safe for use by your invitees, customers, or employees.

Daily Safety Checks are the responsibility of the equipment owner or caretaker. The Following safety checks are to be done daily and/or after any electrical power outages:

1. When actuated, the door should slowly open at a smooth pace (5 seconds min.) until gently stopping at the pre-set fully open position.
2. The door should hold open for the pre-set time of not less than 5 seconds
3. The door should then slowly close at a smooth pace (5 seconds min.) and stop gently.
4. Make sure the traffic path and threshold area are clean and clear inside and outside of doorway
5. Inspect the door, safety decals, connecting arms, hardware and glass for wear or damage.

NOTE: The Association of Automatic Door Manufactures (AAADM) has established a program to certify automatic door inspectors. Through this program, the inspectors are trained to check your door systems for compliance with the American National Institute's standard ADSI/BHMA A156.10

WARRANTY:

Quad Systems, LLC (seller) warrants to the Buyer all products which Quad Systems, LLC manufactures to be free from defects in material and workmanship, under normal use and service, for twelve months from the date product is purchased. The Seller's obligation under this warranty is limited to the repair or replacement at the factory, of any parts which shall be returned to the Seller with transportation charges prepaid and which after examination, prove to be defective. This warranty shall not apply to such products which have been altered or repaired by other than an authorized agent. Authorization shall be in writing by Quad Systems, LLC. Warranty does not apply if products have been subject to misuse, negligence or accident.

There is no expressed or implied warranty by Quad Systems, LLC except as specifically stated above.

Quad Systems, LLC shall not be liable for special or consequential damage, nor for claims of any third party against the buyer.

NOTE: Quad Systems, LLC units are identified by serialized numbers (stamps or stickers) and recorded by sales purchase order numbers, date sold, date made and date tested. Removal or defacing of serial number tags will void warranty.

SERVICE AVAILABILITY:

Quad Systems, LLC products are distributed throughout the United States and Canada by a network of authorized distributors for sales, installation and service.

IF YOUR AUTOMATIC DOOR IS NOT WORKING PROPERLY, **TURN IT OFF** AND CALL YOUR AUTOMATIC DOOR SUPPLIER.

Quad Systems, LLC

EZ-4000 Automatic Door Operator

Mounting Instructions

Attention: Important Installation Instructions. Read and follow all Installation Instructions. Save these Instructions.

This device is to be installed by an experienced, trained installer in accordance with **ANSI A156.19 American National Standard for Power Assist and Low Energy Power Operated Doors** as well as all local codes.

WARNING: The **EZ-4000** may be used for Residential or Commercial interior doors **only** with widths up to 48" (1220 mm) and a maximum weight of 350 lb. (91 kg). The operator can open the door up to an opening angle of 110° for maximum accessibility. All switching devices **must** be in sight of the door it operates.

120-volt electrical supply supplied by others in accordance with all local codes. This unit must be grounded.

Do NOT connect opener to source of power until instructed to do so.

Step One-Mounting the Header

- Make sure the mounting area has proper support for the unit. Wood studs or blocking in wallboard is recommended.
- On each side of the door frame the header should overlap by 1 1/2" on each side. If the header does not overlap each side by 1 1/2", the output shaft should measure 4" from center to the inside of the hinged side of the opening.
- The bottom of the unit should be 3/4" to the inside of the doorframe (see drawing below).
- Drill holes in back of header and install a minimum of 6 correct fasteners for the wall material. The unit **must** be mounted level and in a secure manner.

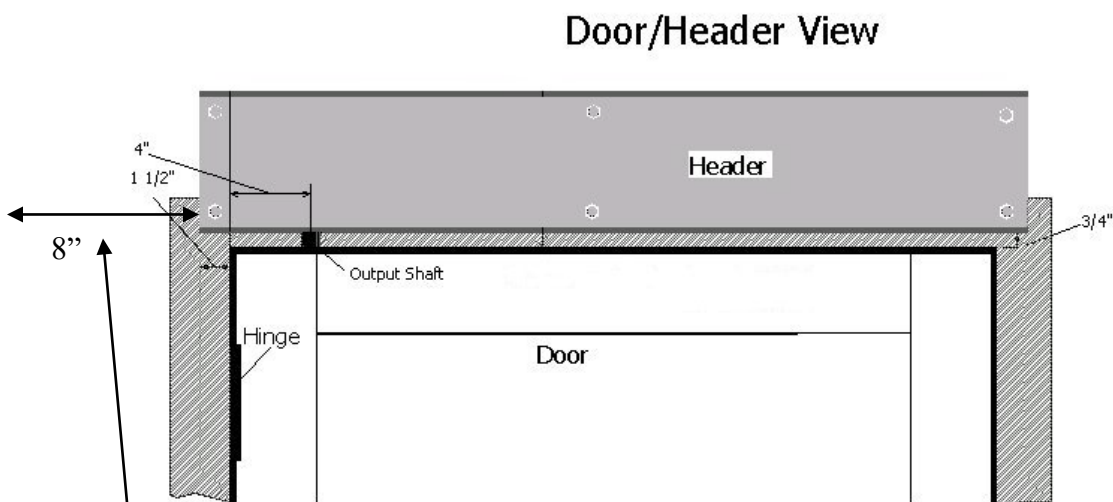

NOTE: If door is an In-Swing, allow 8" minimum between header and opposing wall to allow clearance for the Pull Arm.

Step Two-Mounting Operator-Controller

- Move square nuts provided in header slots to pre-marked positions.
- Lift unit into header and secure with the 4 bolts provided making sure output shaft is at center of opening.

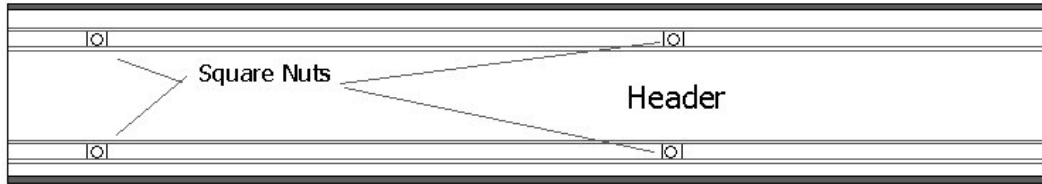

WARNING: The closing speed control is built into the Controller. **DO NOT** wind or rotate the motor until the Controller is installed and plugged in or serious damage could be inflicted on the Controller as well as the installer.

- Install the Hold-Open-Automatic (HOA) switch into the end cap hole provided on each end and plug in wiring harness from switch and operator into marked pins.

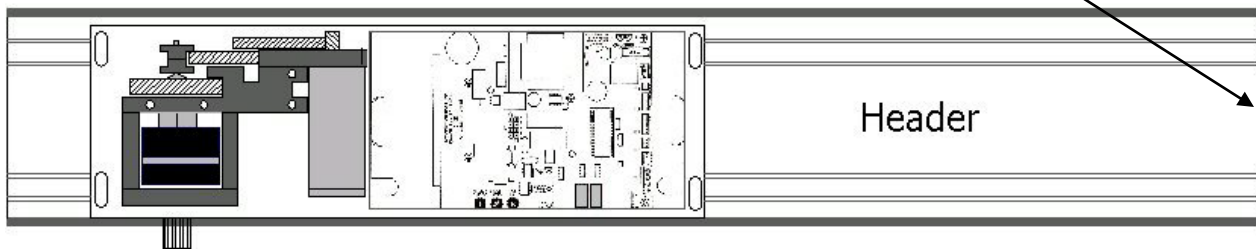

WARNING: Do NOT connect opener to source of power until instructed to do so.

NOTE: At this point do **not** install any other device into the controller i.e., operator harness lock harness, safety harness, radio harness, etc...

Step Three-Mounting the Arm, Rod and Rod Swivel

- Install Rod Swivel as shown below using dimension chart below.

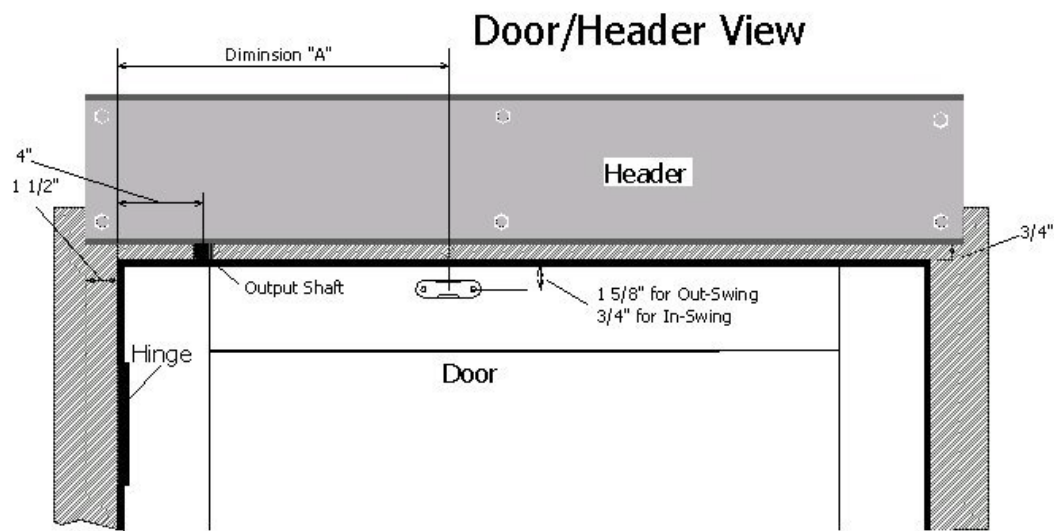

Installing Power Arm and Rod

- Prepare Power Arm and Rod as per drawings and charts.

| REVEAL In Inches | BUTT HINGE OR OFFSET PIVOT | | | | REVEAL In Inches | CENTER PIVOT 2 3/4" | | | |
|---------------------|----------------------------|---------|-----------|---------|---------------------|---------------------|---------|-----------|---------|
| | IN SWING | | OUT SWING | | | IN SWING | | OUT SWING | |
| | DIM "A" | DIM "B" | DIM "A" | DIM "B" | | DIM "A" | DIM "B" | DIM "A" | DIM "B" |
| 0 | 13 | 10 | 16 | 17.5 | 0 | 17 | 9 | 16 | 16.5 |
| 0.5 | 13 | 10 | 16 | 17.5 | 0.5 | 17 | 9 | 16 | 17 |
| 1 | 13 | 10 | 16 | 18 | 1 | 17.5 | 9.5 | 16 | 17.5 |
| 1.5 | 14 | 10 | 16 | 18.5 | 1.5 | 17.5 | 9.5 | 16 | 18 |
| 2 | 14 | 10.5 | 16 | 18.5 | 2 | 18 | 10 | 17 | 18.5 |
| 2.5 | 14 | 11.5 | 16 | 19.5 | 2.5 | 19 | 10.5 | 17 | 19 |
| 3 | 15 | 12.5 | 16 | 19.5 | 3 | 19 | 10.5 | 18 | 20 |
| 3.5 | 16 | 11 | 16 | 20.5 | 3.5 | 19 | 11.5 | 18 | 20.5 |
| 4 | 17 | 12 | 17 | 20.5 | 4 | 25 | 12 | 19 | 20.5 |
| 4.5 | N/A | N/A | 18 | 21.5 | | | | | |
| 5 | N/A | N/A | 18 | 23 | | | | | |
| 5.5 | N/A | N/A | 18 | 23 | | | | | |
| 6 | N/A | N/A | 18 | 24 | | | | | |
| 6.5 | N/A | N/A | 18 | 24 | | | | | |
| 7 | N/A | N/A | 18 | 24.5 | | | | | |
| 7.5 | N/A | N/A | 18 | 24.5 | | | | | |
| 8 | N/A | N/A | 18 | 25.5 | | | | | |
| 8.5 | N/A | N/A | 18 | 25.5 | | | | | |
| 9 | N/A | N/A | 18 | 26.5 | | | | | |
| 9.5 | N/A | N/A | 18 | 26.5 | | | | | |
| 10 | N/A | N/A | 18 | 26.5 | | | | | |
| 10.5 | N/A | N/A | 18 | 27.5 | | | | | |
| 11 | N/A | N/A | 18 | 27.5 | | | | | |
| 11.5 | N/A | N/A | 18 | 28.5 | | | | | |
| 12 | N/A | N/A | 18 | 28.5 | | | | | |
| 12.5 | N/A | N/A | 18 | 29 | | | | | |
| 13 | N/A | N/A | 18 | 29.5 | | | | | |
| 13.5 | N/A | N/A | 18 | 30 | | | | | |
| 14 | N/A | N/A | 18 | 30.5 | | | | | |
| 14.5 | N/A | N/A | 18 | 31 | | | | | |
| 15 | N/A | N/A | 18 | 31.5 | | | | | |
| 15.5 | N/A | N/A | 24 | 24 | | | | | |
| 16 | N/A | N/A | 24 | 24 | | | | | |
| 16.5 | N/A | N/A | 24 | 24 | | | | | |
| 17 | N/A | N/A | 24 | 24 | | | | | |
| 17.5 | N/A | N/A | 24 | 24 | | | | | |
| 18 | N/A | N/A | 24 | 24 | | | | | |
| 18.5 | N/A | N/A | 24 | 24 | | | | | |
| 19 | N/A | N/A | 24 | 24 | | | | | |
| 19.5 | N/A | N/A | 24 | 24 | | | | | |
| 20 | N/A | N/A | 24 | 24 | | | | | |
| 20.5 | N/A | N/A | 24 | 24 | | | | | |
| 21 | N/A | N/A | 24 | 24 | | | | | |

Quad Systems does not recommend In-Swing reveals over 4 inches without a qualified engineers input.

Lengths in borders require extra long Rod. Part # EX-24.5

PARALLEL ARM AND TRACK INSTALLATION

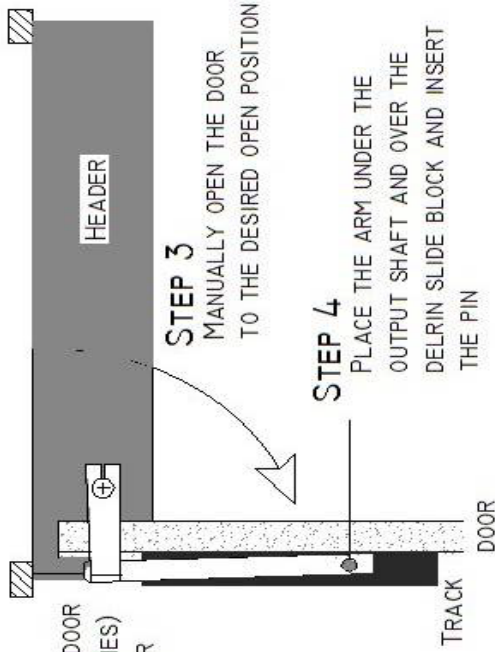

STEP 1
 -INSTALL TRACK ON DOOR 1" FROM TOP OF DOOR
 (1 1/8" IF REVEAL IS MORE THAN ZERO INCHES)
 -MARK HOLES AND DRILL #7 HOLES IN DOOR
 -MOUNT TRACK WITH # 14 X 3" SCREWS
 PROVIDED

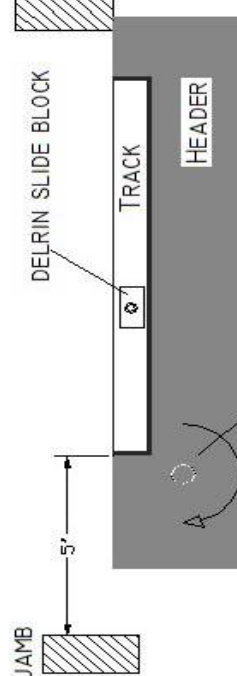

STEP 2
 TURN ON THE UNIT AND PLACE ON "HOLD OPEN"
 TO ROTATE SHAFT TO MAXIMUM OPEN POSITION

STEP 3
 MANUALLY OPEN THE DOOR
 TO THE DESIRED OPEN POSITION

STEP 4
 PLACE THE ARM UNDER THE
 OUTPUT SHAFT AND OVER THE
 DELRIN SLIDE BLOCK AND INSERT
 THE PIN

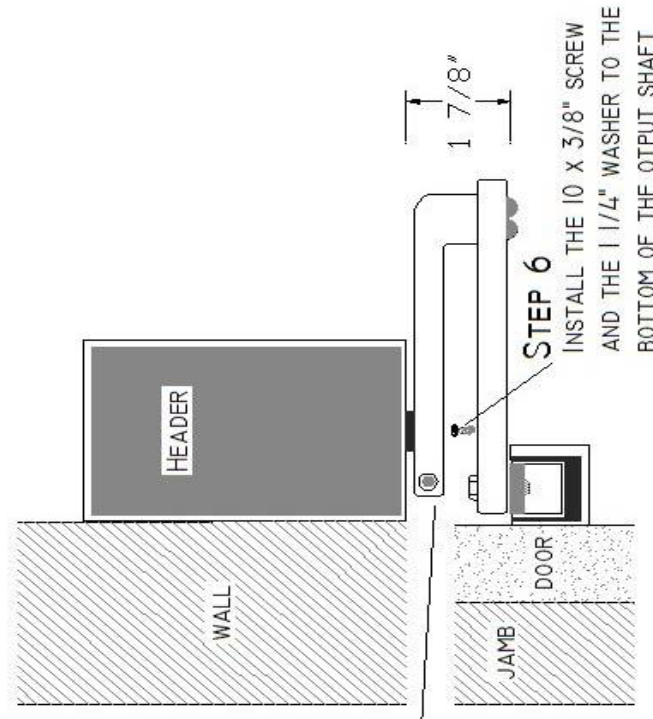

STEP 5
 INSTALL THE ARM TO
 THE OUTPUT SHAFT
 AND TIGHTEN THE
 1/4" X 1" SCREW TO 10
 FOOT-POUNDS

STEP 6
 INSTALL THE 10 X 3/8" SCREW
 AND THE 1 1/4" WASHER TO THE
 BOTTOM OF THE OUTPUT SHAFT

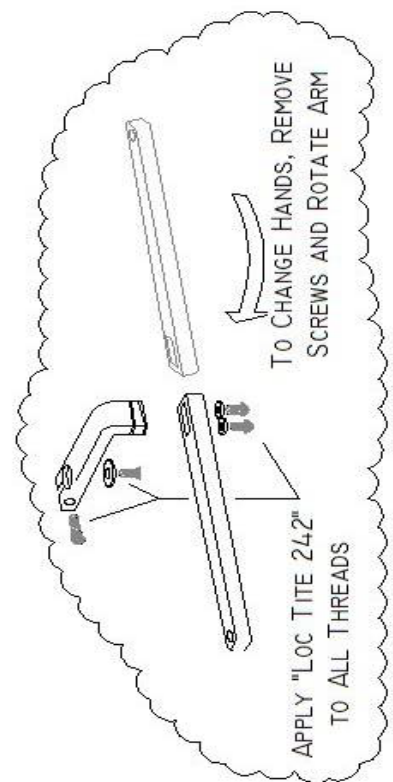

ES-500 Swing Control Installation

WARNING: When used in a low energy installation, the **EZ-4000** operator and associated **ES500** control **must** be installed and adjusted in accordance with **ANSI 156.19** documentation.

WARNING: The **ES500** control must remain connected to the operator at all times. Never leave the operator without a control connected, as the closing speed will be uncontrolled and may cause severe damage to the operator or door. Manual operation must never be permitted with the control removed.

1.0 Wiring – On/Off Switch and Incoming Power

If the installation consists of a synchronized pair of operators, see the special note on page 5.

Install the supplied **on/off/hold** switch in the desired location and route the switch lace into the header. Plug the connector into **SWTCH** input **CN4** on the control.

Verify that the circuit breaker in the **AC** panel supplying power to the operator is **off**. Connect the power cable supplied to the incoming wires (black, red or blue incoming in to black on power cable and the white wire to the white wire). The incoming ground wire must be connected to the frame of the operator using the ground screw provided. Restore power via the building circuit breaker, but do not plug the line power harness into the control yet.

The actuating devices, plus any optional devices, will be wired in a later step. If a lock is present, temporarily disable it to keep it from jamming the door while setting up the operator.

2.0 Initial Setup

WARNING: In the next step you will be applying power to the operator in order to install the operator arm. **Avoid all moving parts!**

Turn the unit on and set the **on/off/hold** switch to the “**Hold**” “=” position. Physically inspect the operator to ensure that it is against the internal open stop. Next, position the door at the full open position and securely install the arm on the operator. The exact steps needed will vary depending on the type of door installation (in-swing or out-swing). Refer to the operator instructions for further details.

1.2 Adjustment Procedure

During the following sections, if any delays, options, or speeds (other than the closing speeds) need adjustment, switch the **on/off/hold** switch to the **off** position. An indicator on the display will begin winking, and the display will switch to the menu of adjustable parameters. Use the **UP** or **DOWN** buttons to find the parameter you wish to change. When you have located it, **press and hold** the **SET** button. The display will change to the current value of that parameter. While continuing to hold the **SET** button, use the **UP** or **DOWN** buttons to find the new value you wish to use. When you've

found it, release the **SET** button. Switch the door back on and check the operation using the new value(s). Refer to Section 1.7, Parameter List, for descriptions of the parameters and their factory defaults.

Important: Be sure to save any changes you make before leaving the jobsite! **Changes are not stored in the ES500 control's permanent memory until you save them.** To save your parameters, with the door in normal operation, press **and hold** the **SET** button until the display winks **dS** (data Saved). Your parameters are now stored in the control's permanent memory.

WARNING: The **LIMIT**, **OBST**, **CLS SPD**, and **LAT SPD** screwdriver adjustments are in close proximity to electrically hot parts. Be careful to avoid contact with any parts while making adjustments.

1.3 Closing Adjustments

After the arm is installed, turn the **on/off/hold** switch to the “**Off**” position. The door will close. Physically inspect the latch check switch (switch with the blue, gray, and white wires) and its associated cam. The switch arm should be on the **CENTER** flat side of the cam. (**The arm of the latch check switch should remain depressed from the fully open position until the door is approximately 10-15° from the full closed position, and then it must release.**) Adjust the cam as necessary. Next, adjust the **CLS SPD** (close speed) and **LAT SPD** (latch speed) pots for the desired closing operation. **DO NOT ADJUST WHEN THE DOOR IS IN MOTION.** The door may be manually opened as many times as necessary to complete these adjustments.

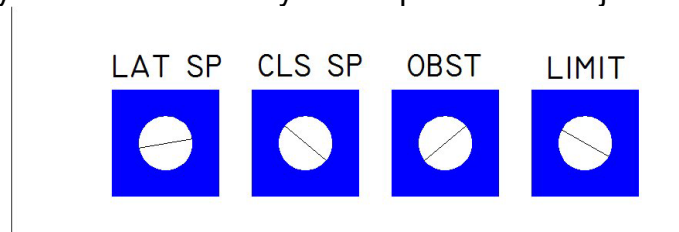

1.4 Opening Adjustments

Turn the **on/off/hold** switch to the “**Hold**” position and let the door fully open. Physically inspect the open check switch (switch with orange and yellow wires) and its associated cam. The switch arm should be on the **CENTER** flat side of the cam. (**The arm of the open check switch should remain depressed until the door is approximately 30° from the fully open position, and then it must release.**) Do not proceed further until you have verified the adjustment of this cam.

Temporarily set both the **LIMIT** pot and the **OBST** pot fully counterclockwise. Insure that the **on/off/hold** switch is in the **ON** position.

After all the settings are set be sure to save the program. With the door closed and the display reading **Id** (Idle) press and hold the set button until the display changes to **dS** (data Saved).

HINT: If the door remains closed but the display does not switch to **Id**, insure that the latch check cam has been adjusted properly (Section 1.3, Closing Adjustments) and that the rocker switch is in the **ON** position. If the door tries to open, insure that the rocker switch is not in the **HOLD** position instead of the **ON** position.

Cycle the door by pressing and holding the **DOWN** button (this button functions as an actuate signal when the door is in normal operation, allowing easier testing). The door should cycle open. The display will show **OS** (Open Speed) before the open check switch releases. It will switch to **OC** (Open Check) in the open check zone. If the **DOWN** button is held long enough, the display will switch to **HO** (Hold Open).

When the **DOWN** button is released, the door will begin closing after the **d1** time delay expires. Cycle the door several times using the **DOWN** button and check for proper operation. If any speeds or delays need to be changed, follow the instructions in Section 1.2, Adjustment Procedure.

WARNING: The following two paragraphs describe the limit and obstruction sensing features of the ES500 control. The limit feature **must** be set properly for low energy applications. It is also highly recommended that the **obstruction**-sensing feature be used for maximum pedestrian safety. The **open speed** and **check speeds** should be properly set before attempting to adjust the added safety features.

The **limit** feature, when properly adjusted, allows faster open speed while maintaining safety by limiting the maximum torque output of the operator. Adjust the **LIMIT** pot clockwise to reduce the opening force to the desired maximum. Clockwise adjustment increases the limiting and reduces the force available.

The **obstruction** sensing feature of the **ES500** control, when properly adjusted, switches the door to a much lower hold-open force if an obstruction is encountered during door opening. Adjust the **OBST** pot clockwise sufficiently to obtain an obstruction response when an obstruction is encountered. When an obstruction is sensed, the display will switch from **OS** to **Ob** (Obstruction) and the control will switch to hold open voltage. After a brief delay, the display will switch to **SS** (Seek Speed) and the door will creep the rest of the way open, after which normal operation will be restored. Set the seek speed just high enough to ensure that the door creeps open following an obstruction response timeout.

Note: If the LIMIT adjustment is turned up too far, it may not be possible to get the obstruction response.

1.5 Actuating & Accessory Wiring

Remove power from the control. Wire the actuating device(s) to **ACT** connector **CN2** as shown in the wiring diagram. Note that total accessory device current draw should be limited to 0.5A or less. A radio receiver may be wired directly into **CN2**, or for easier installation, an optional dedicated harness may be plugged into **RADIO** connector **CN3** and wired to the receiver.

The remaining connectors are for optional features and are normally unused in low energy installations. If they are used, wire them as shown in the wiring diagram.

The control directly supports the use of automatic locks of either the mortise or magnetic type. An optional lock harness must be obtained from Quad Systems. If a lock is to be used, wire it to the lock harness as shown in the diagram. Typically, the normally closed relay contact is used with magnetic locks, and the normally open contact for mortise strikes. Be sure to adjust lock parameters **LL** and **UL** as shown in Section 1.7, Parameter List, before attempting operation with a lock. **Do not attempt to power the lock from the control unless the total accessory current draw, including lock, is 0.5A or less.**

After all other devices are wired, power the control back up and check for proper operation. The green **ACT** (ACTuate) indicator should light whenever an external actuating device (including the radio receiver) triggers the door to open. The Red **SAF** (SAFety) or yellow **SNS** (Stop-N-Seek) indicators should light if any of the optional safety devices are active. If any auxiliary switches or devices are used (see the **AF** parameter description below), the yellow **AUX** (AUXiliary) indicator should light whenever they are triggered.

1.6 Display Codes

During normal operation, the **ES500** control displays its current status via the display as follows:

Id Idle, awaiting open command

SA SAFety device active, door prohibited from opening
OS Opening door at Open Speed
OC Opening door at Open Check speed
HO Holding Open
OP Manual Opening detected (with PG turned off)
CL CLosing door, with speed set by close speed adjustment
LC Closing door at Latch Check speed, latch check delay running
SS Opening door at Seek Speed (following obstruction)
Ob Obstruction detected, door stalled**
d1 Time delay 1 in use (delay for normal actuating devices) *
d2 Time delay 2 in use (delay for push and go actuation) *
d3 Time delay 3 in use (delay for touch-stop recycle) *

* These codes flash briefly when the operator switches from open speed to open check to indicate the current time delay in use.

** The obstruction display results from either a door jam condition during opening, *or* from triggering the optional stop-n-peek safety device, if used.

The normal display sequence during a cycle is **OS – d1** (or **d2**) – **OC – HO**, then **CL – LC – Id**.

1.7 Parameter List

The following list shows all adjustable parameters in the **ES500** control, along with a brief description of their function and their factory default values.

OS Open Speed. Sets the opening speed of the door before the open check switch is released. Possible values are 0-15, and default is 4.

OC Open Check. Adjusts from 0-15. Default is 9. Determines opening speed after the open check switch is released (within the last 15-45° of door opening).

HO Hold Open. Adjusts from 0-15. Default is 3. Should be adjusted to the minimum power required to keep the door from drifting closed after the display switches to **HO**.

SS Seek Speed. Adjusts from 0-15. Default is 5. Should be adjusted to make the door creep open following the "obstruction" response (see Section 1.4).

AC ACceleration. Determines how fast the door ramps up to open speed following an actuate command. Possible values are 0-15, and the setup default is 15 (maximum acceleration).

dC deceleration. Determines how fast door slows down after the open check switch is released. Possible values are 0-15. The setup default of 0 switches door immediately from "speed" to "check" with no ramp-down.

UJ UnJam power. Determines amount of power the control applies in the closing direction to unjam the lock and/or door prior to opening. Possible values are 0-16, and the setup default is 0 (do not apply unjam power). Note that unjam power may be used with or without a lock present.

d1 Time delay 1 (standard). Determines the time the door stays open. The time delay begins when the door reduces speed to open check. Possible values are 1-99 seconds, and the setup default is 6 seconds.

d2 Time delay 2 (push and go). This delay is used only when the door has been actuated by a push and go signal. The time delay begins when the door reduces speed to open check. Possible values are 1-99 seconds and the setup default is 1 second.

Note: **d1** takes priority over **d2**. If the door is opened via push and go, then a standard actuating signal (pushbutton etc.) is received, **d1** replaces **d2**.

d3 Time delay 3 (close recycle). This delay is used only when the door has been recycled by an obstruction detected while attempting to close. The time delay begins when the door reduces speed to open check. Possible values are 1-99 seconds, and the setup default is 1 second.

*For paired operation, **d3** must be set the same as **d1***

LC Latch Check delay. This delay begins when the door reduces speed to latch check. It should be set to ensure that the door is fully closed before the display switches from **LC** to **ld**. It prevents the safety devices, if any, from being re-enabled too early during the closing sequence. The safety devices are automatically "locked out" while the door is closing (display shows **CL**) and while the latch check delay is running as well (display shows **LC**). Possible values are 1-99 seconds; default is 3 seconds.

UL UnLock delay. This delay should be set to ensure that the lock retracts before the door begins opening. It is displayed in 0.1second intervals, and possible intervals are 0.1-9.9 seconds. The default of 0.8 seconds is sufficient for most magnetic locks.

AF Auxiliary Function. This parameter defines the function of auxiliary input connector **CN7**. The default value of 1 enables **CN7** to be used as a close monitor switch input. Setting **AF** to 2 allows this connection to be used for approach side sensors that function only as recycle/hold open devices (the devices are ignored when the door is closed). Setting **AF** to 3 allows this connection to be used for a safety beam input. Other values of **AF** are reserved and disable the **CN7** input when selected.

ct Cycle Test. This cycles the door at regular intervals for testing. Default is off.

PG Push And Go. This automatically completes a cycle if someone begins pushing the door open manually. Default is off (no push and go). Also see the **d2** parameter.

Cr Close recycle. This recycles the door open if an obstruction is encountered prior to the door entering latch check. Default is on.

SL SLower open speeds. This reduces all open speed settings by approximately 50%, allowing the use of very slow open speeds if desired. Remaining speeds (open check, hold open, etc.) are not affected by **SL**. Default is off (use normal open speeds).

LL Lock present. When the **LL** parameter is on, the control will trigger the lock relay prior to opening. It will also attempt to unjam the door, if requested (see the **UJ** and **UP** parameters), and will wait through the unlock delay (see the **UL** parameter) before opening the door. Default is off (no lock).

HS Hold Strike. If the **HS** parameter is left off, the lock will be released approximately 1 second after the door begins opening. This is normally the preferred setting, as it prevents burn out or buzzing of inexpensive mortise type strikes. If **HS** is turned on, the lock will be held in the released condition for the total duration of the open cycle, the close cycle, and the latch check delay (see the **LC** parameter). Default is off (do not hold strike through open cycle).

U1-3 User Parameters 1-3. These parameters adjust from 0-99 and are not used in any way by the control itself. They may be set to any data the installer wishes to save (month/year of installation, date of last service, technician code, etc.).

SPECIAL NOTES ON SYNCHRONIZED PAIRS

A six-conductor synchronization harness is supplied with paired operators. It is strongly suggested that this harness be left unplugged until each door of the pair is set up properly and operating normally as an independent unit. The harness may then be plugged into **SYNC** connector **CN5** on each control to synchronize the two doors.

Connections for actuating and safety devices as well as the **on/off/hold** switch may be made to **either** control. It is not necessary to connect them to both.

Due to the method used for synchronization, it is not possible to have different values for the standard delay (**d1**) and the close recycle delay (**d3**). Delays **d1** and **d3** should be set to the same value in each operator, and must also be set identically on both operators. The push-n-go delay (**d2**) may be different from **d1/d3**, but should also be set identically on both operators. This restriction does **not** apply to single operators.

EZ-4000 Power Consumption

The measured currents and power consumptions for the EZ-4000 operator are as follows:

- Idle, door closed: 0.066 amperes, 8 watts
- Opening, operator only (no door attached), peak measurement: 0.46 amperes, 56 watts
- Holding open: 0.265 amperes, 32 watts

The opening power will be somewhat higher with a door attached to the operator. A conservative estimate would be a factor of roughly two times the given figure (0.82 amperes or 112 watts) for any reasonable door weight (up to 100-125 pounds).

The control has a 3.15 ampere fuse, so in no case will the prolonged current draw be more than this figure, as the fuse would blow.

Another question which seems to be asked frequently regards cost of operation. It is estimated that the cost of operation is well below \$0.01 per door cycle.

It was also determined that if the door is held open all day long, 24 hours a day, the total cost per month is \$2.84.

The dollar figures given are based on energy cost of \$0.12 per kilowatt hour.

QUAD SYSTEMS

ES-500 "PIN OUT"

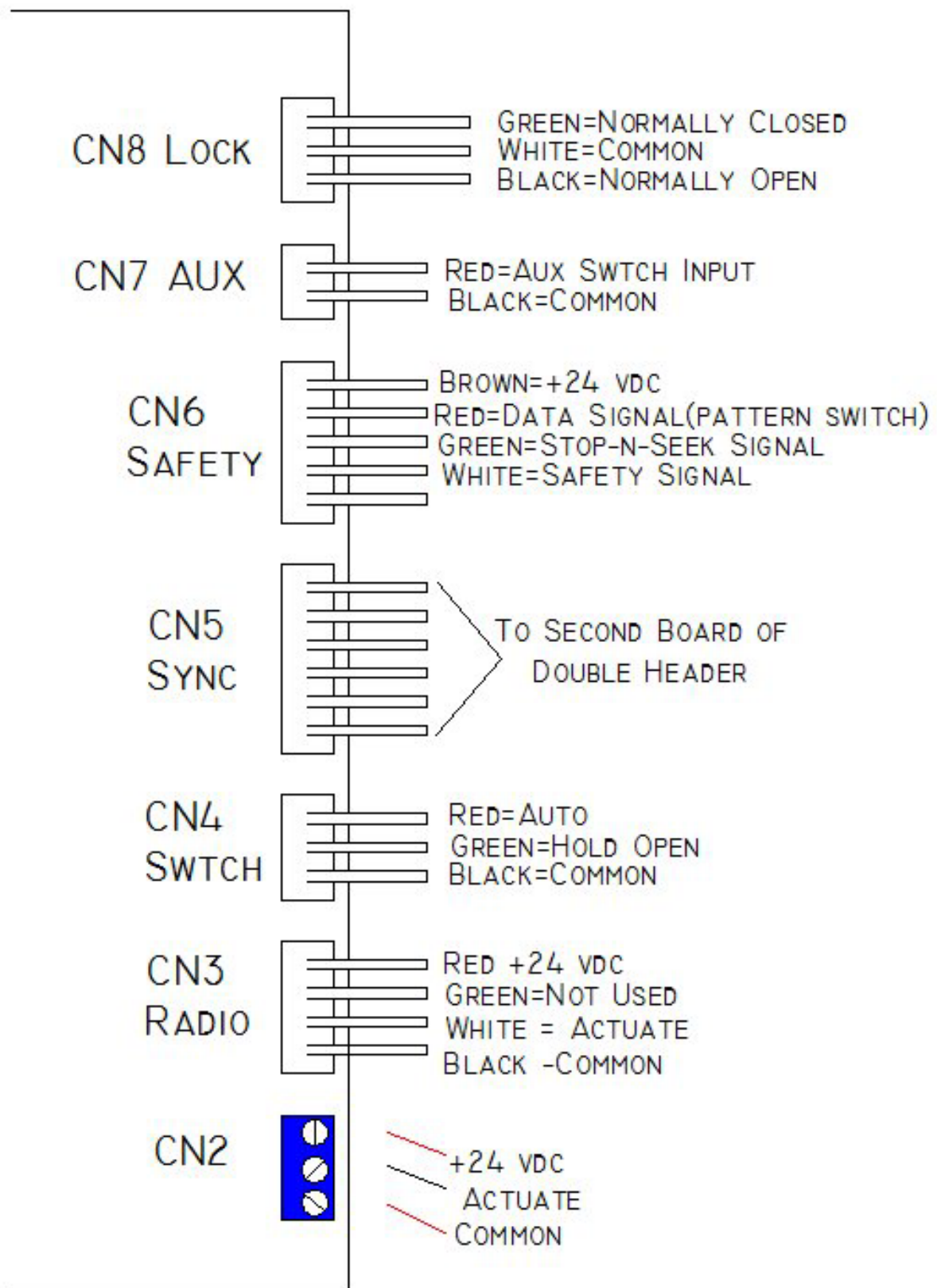

Larco Wireless Receiver to Quad Systems ES-500 PCB

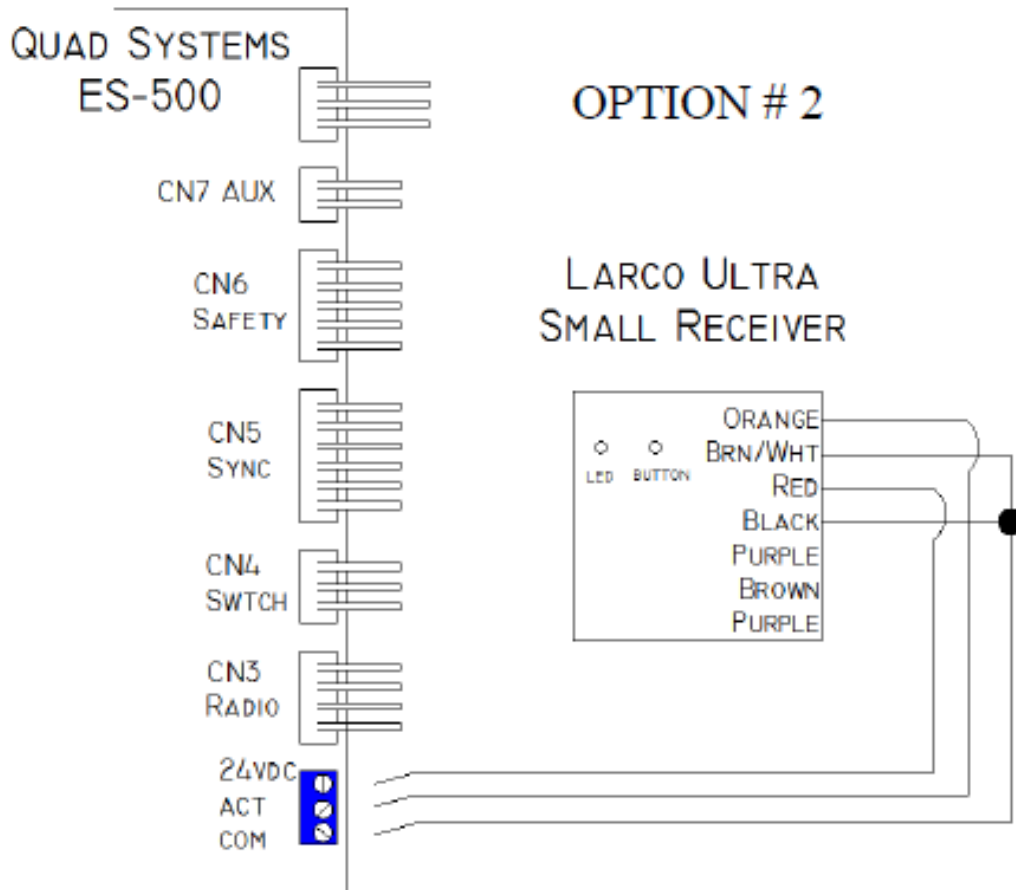
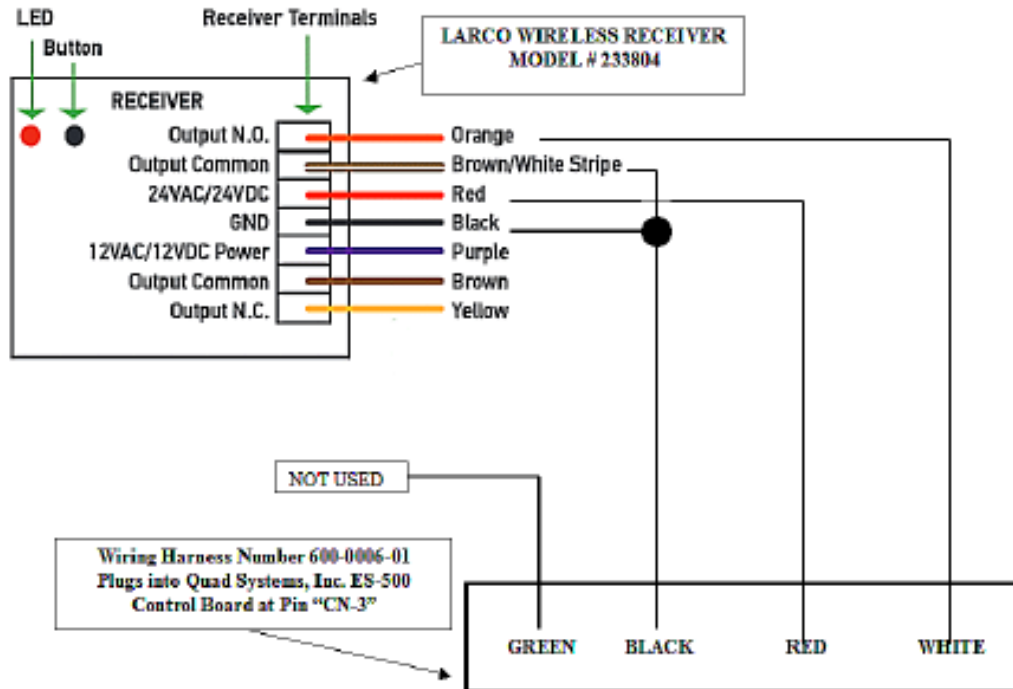

Lock with No Transformer (not recommended)

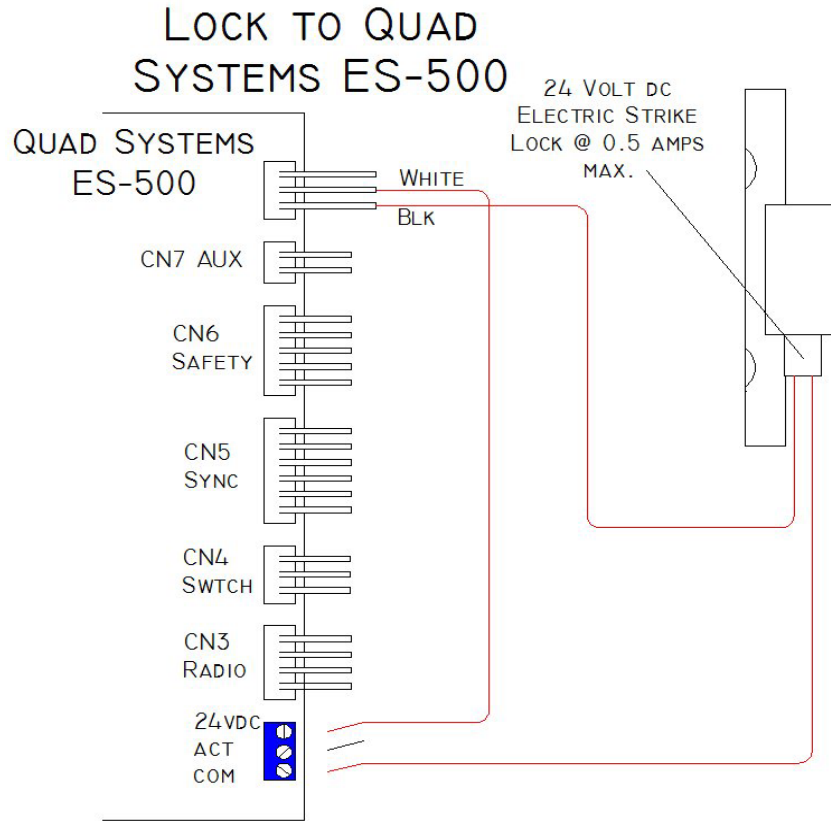

Lock with Transformer (recommended)

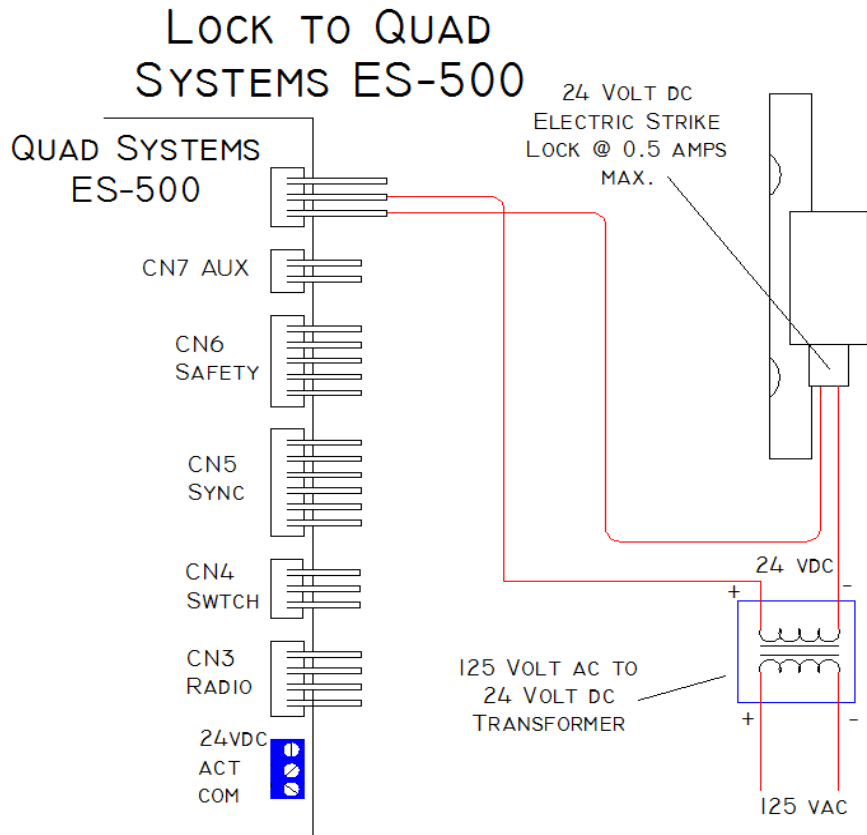

OPTEX SENSORS TO QUAD SYSTEMS ES-500

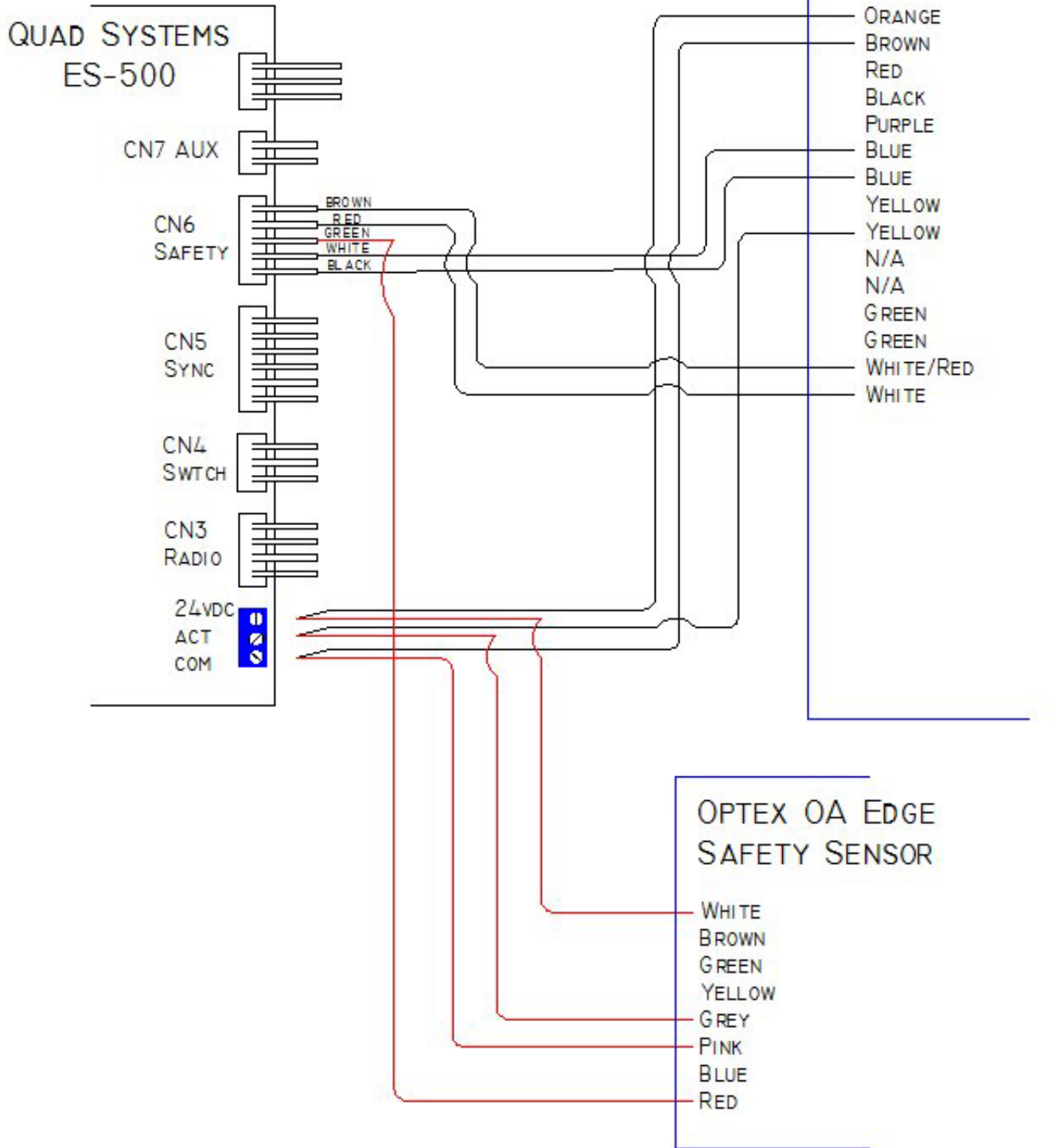

Optex Technical Support 800-966-7839

INSTALLATION NOTES

1. Set door speeds, force, time delay and verify proper door operation prior to final connection of sensors system.
2. Primary activation must be Knowing Act. If not then technician MUST WALK TEST to verify function and detection patterns comply with ANSI/BHMA A156.10 requirements.
3. On Knowing Act applications, push/pull activation must be disabled.

Note: Optimal OC-904C T Yellow wires connection point. When the OC-904C T Yellow wires are connected to CN7. Auxiliary Function (AF) the parameter value must be set to (2). This will cause the activation signal from the approach side OA-603 T to be ignored when the door is in the close position.

Quad Systems ES-500

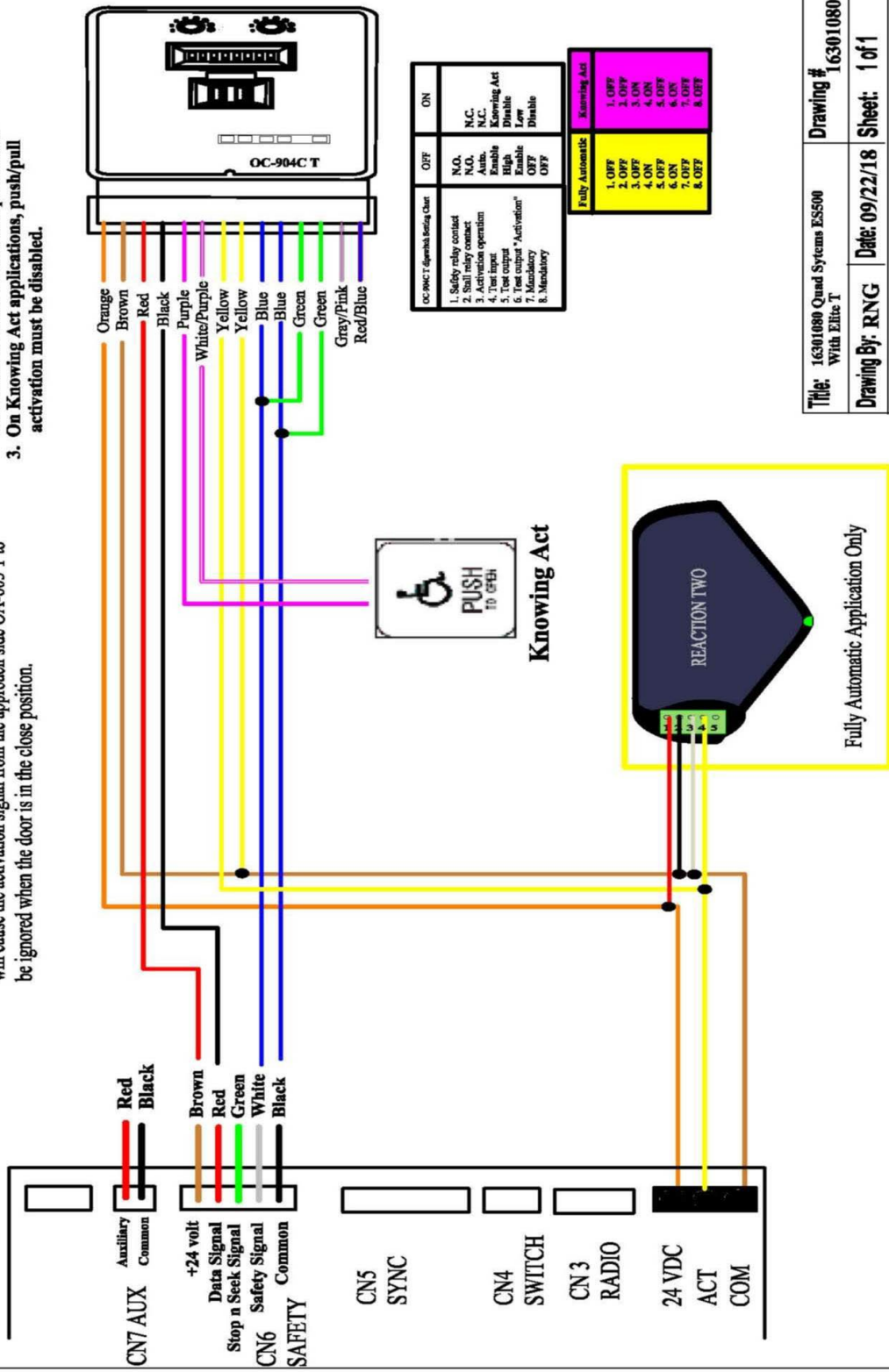

| OC-904C T Signal Setting Chart | OFF | ON |
|--------------------------------|---------|-------------|
| 1. Safety relay contact | N.O. | N.C. |
| 2. Stall relay contact | N.O. | N.C. |
| 3. Activation operation | Auto. | Knowing Act |
| 4. Safety Disable | Disable | Enable |
| 5. Test output | Enable | Test |
| 6. Test output "Activation" | OFF | OFF |
| 7. Mandatory | OFF | OFF |
| 8. Mandatory | OFF | OFF |

| Fully Automatic | Knowing Act |
|-----------------|-------------|
| 1. OFF | 1. OFF |
| 2. OFF | 2. ON |
| 3. OFF | 3. ON |
| 4. OFF | 4. OFF |
| 5. OFF | 5. ON |
| 6. ON | 6. ON |
| 7. OFF | 7. OFF |
| 8. OFF | 8. OFF |

Title: 16301080 Quad Systems ES500 With Elite T Drawing # 16301080

Drawing By: RNG Date: 09/22/18 Sheet: 1 of 1

Optex Technologies Inc.
18730 S Wilmington Ave Unit 100
Rancho Dominguez, CA. 90220
Office: (800)877-6656, Fax: (310)898-1098



Frequently Asked Questions About the ES-500 Controller and Quad Systems, LLC. EZ-4000 Operators

Q. Can the Quad Systems operator be used with a Horton control?

A. Yes, in most cases the **ES-4000** operator can be used with the Horton C4160-1, C4160-2, C4190, or C7160-3 controls. An adapter harness would be required to allow the **EZ-4000** to plug into the Horton control. The harness would have the proper connectors on each end and would also include the brown wire for the open check micro-switch, which Horton's C7160-3 control requires (Quad Systems ES-500 control does NOT require this connection, so it is not present in the current operator wiring harness).

Q. Can our control be used with a Horton operator?

A. Yes, the **ES-500** can be used with the Horton S7000 or S4000 operator. An Adapter harness (part number 600-0011-02) is required and includes detailed installation instructions.

Q. How do I easily adjust the cams?

A. Place switch on "Hold-Open" (=) position and let the door open to the full open position. Loosen the small Allen head screws on the outside cam (switch with 2 wires). Rotate the cam until the switch is on the flat part of the cam and tighten screw. Place switch in the "Off" (o) position and let the door close completely. Loosen the small Allen head screws on the inside cam (switch with 3 wires). Rotate the cam until the switch is on the flat part of the cam and tighten screw.

Q. I need a motion sensor (or a door mounted approach sensor) that is disabled when the door is fully closed--that is, I only want it to function as a recycle and hold open device for additional safety. It must be ignored when the door is closed. How can I make this possible?

A. This feature is supported beginning in Versions 1.02/1.03. An auxiliary harness (Close Monitor harness, (part number 600-0008-01)) will be required. Set the AF parameter to 2*. Wire the additional sensor's output contact to the red and black wires of the auxiliary harness.

Q. How can I install door mounted, swing side sensors that slow/stops the door if a pedestrian is detected as the door is opening?

A. A door mounted swing side sensor may be installed with the use of a Safety harness (part number 600-0007-01). Wire the sensor's output contact to the green and black wires (Stop-N-Seek input) of the Safety harness.

Q. How does the "UL" setting work?

This setting will delay the opening of the door after being activated and will require the "LL" setting to be turned on.

Q. How does a safety mat function?

A. A safety mat will have two wires which will be connected to the black and wire wires of the Safety harness (600-007-01). If someone is standing on the mat, the switch or sensor will not open the door. If someone opens the door and stands on the mat, the door will not close. After the person steps off the mat the ES-500 will start the "HO" cycle then close.

Q. I am using the operator in a high energy mode. How can I acquire support for a safety beam per ANSI 156.10?

A. Although Quad Systems does not recommend the use of this operator and/or control in a high energy mode, this feature is supported beginning in Versions 1.02/1.03. An auxiliary harness (Close Monitor harness, (part number 600-0008-01) will be required. Set the AF parameter to 3*. Wire the safety beam's output contact to the red and black wires of the auxiliary harness. A beam break will prevent the door from opening if it's closed, prevent it from closing if it's open, slow the door to seek speed if it's opening, and will immediately cancel the lockout delay and re-engage the safety sensor if the door is closing.

Q. What transient filter is built into the control?

A. The control has the industry standard metal oxide varistor (MOV) surge absorber built in. It is rated for 150VAC continuous, 20 joules, and is located downstream of the slow blow fuse. Short overvoltage conditions are typically absorbed by the MOV with no control damage, while prolonged ones (such as accidental connection to the wrong supply voltage) will normally blow the fuse.

Q. Is there any kind of gate to kill spikes?

A. The MOV discussed above would be considered the "gate" that kills spikes. There is also a part called a 'Surge Limiter' on the control. Its function is to reduce the initial surge when the control is powered up, prolonging the life of certain components on the control.

4000 Series **Default** Programming
For ES-500 Board with
113-0102-00 Chip

OS-6
OC-4
HO-3
SS-6
AC-5
DC-3
UJ-0
D1-6
D2-1
D3-1
LC-3
UL-8
AF-1
Ct-of
PG-of
Cr-on
SL-on
LL-of
HS-of
U1-not used
U2-not used
U3-not used

Highlighted items are unique for this
Operator

EZ-7000 & 28k Series **Default**
Programming for ES-500 Board with
113-0102-01 Chip

OS-2
OC-4
HO-3
SS-6
AC-3
DC-3
UJ-0
D1-6
D2-1
D3-1
LC-3
UL-8
AF-1
Ct-of
PG-of
Cr-on
SL-of
LL-of
HS-of
U1-not used
U2-not used
U3-not used

Highlighted items are unique for this
Operator



NOTE: If installing a lock controlled by this board the LL function **MUST** be turned on.

For additional programming parameters and instructions see the installation instructions.

See "Power Assist Supplement" for programming Power Assist Chips.